

Mini-Excavator Ax-u-6A Series

AX33u-6A / AX38u-6A / AX48u-6A / AX55u-6A

SAFETY

- Operate safely in accordance with the proper operation manual.
- To prevent trouble and accidents, make sure to perform daily and preventive maintenance checks.

AIRMAN®

HOKUETSU INDUSTRIES CO., LTD.

8th Floor Shinjuku San-Ei Bldg,
22-2 Nishi-Shinjuku 1-Chome, Shinjuku-ku, Tokyo 160-0023 Japan
Tel: 81-3-3348-7281 Fax: 81-3-3348-7289
E-mail: airman.oversea@airman.co.jp
<http://www.airman.co.jp>

AIRMAN ASIA SDN. BHD.

Suite A-8-2, level 8, Block A, Sky Park @ One City,
Jalan USJ 25/1, 47650 Subang Jaya, Selangor, Malaysia
Tel: 60-3-5036-7228 Fax: 60-3-5036-7226
E-mail: sales@airman-asia.com

HOKUETSU INDUSTRIES EUROPE B.V.

Aalsmeerderdijk 156, 1438 AX Oude Meer, The Netherland
Tel: 31-20-6462636 Fax: 31-20-6462191
E-mail: info@hokuetsu.nl

AIRMAN USA CORPORATION

7633 Adairsville Hwy Adairsville, GA 30103
Tel: 1-770-769-4241 Fax: 1-770-769-4335

DISTRIBUTOR :



AX55u

AX55u

HOKUETSU INDUSTRIES CO., LTD.

Efficiency & Comfort

An operating space designed for the ultimate ease of use.
Energy-saving systems that contribute to reducing fuel costs.
Improved maintainability in every detail.

By improving operator ease of use as well as providing advanced functions and high performance for digging, loading, leveling, and other work (utility), we have created a new mini excavator that is certain to satisfy customers.



AX33U-6A Operating weight **3,130kg** Capacity **0.09m³**
Rubber shoes, 4-pole canopy



AX38U-6A Operating weight **3,710kg** Capacity **0.11m³**
Rubber shoes, cabin



AX48U-6A Operating weight **4,540kg** Capacity **0.14m³**
Rubber shoes, 4-pole canopy



AX55U-6A Operating weight **5,210kg** Capacity **0.14m³**
Rubber shoes, Cabin, longarm, countweight



Superior & Ergonomic Friendly with Increased Efficiency

The AX-u series ensures that your work is always carried out efficiently with its improved operability and full range of energy-saving functions.



Hydraulic pilot type control system

The pilot levers have been positioned for ergonomic performance, and the levers are highly rated for their precision operability. The use of a hydraulic pilot system for all controls reduces the required lever operating force.



Fast & smooth multi-axis operations

- The AX33u/38u delivers even greater work efficiency with an improved combination of our popular 3-pump hydraulic system and arm regeneration circuit.
- The AX48u/55u delivers even greater work efficiency with an improved combination of a hydraulic circuit "AHCS" and arm regeneration circuit.

Automatic speed change system for high-speed travel

When the machine encounters a slope or other high load during high-speed travel, it automatically shifts to low speed, then restores high speed when the load decreases.

Automatic idling function

When the operating lever is left in the neutral position for 4 seconds, the engine automatically switches to the idling speed to help reduce fuel consumption and noise.

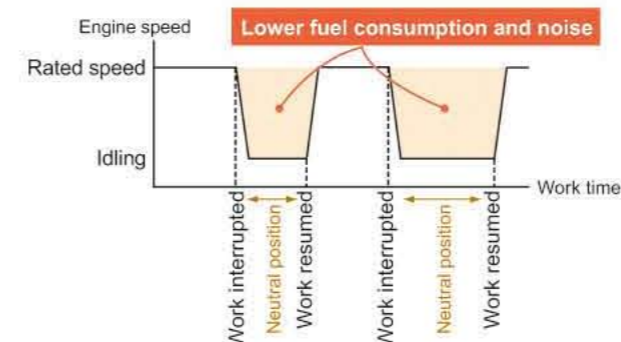

Automatic idling stop function (optional) **New**

This energy-saving system automatically stops the engine when it has been idling continuously for a long period of time. The time before the engine stops can be selected (3 minutes, 5 minutes, 10 minutes, or 15 minutes).



High visibility multi-monitor **New**

A display that communicates the fuel level, coolant temperature, warning lamps, and other machine status information to the operator is installed at the front right.



Display items

- Coolant temperature gauge
- Fuel gauge
- Hour meter
- Clock
- Travel mode indicator
- Work light indicator
- Engine indicators
- Overheat indicator
- Engine oil pressure indicator
- Charge indicator
- Fuel level indicator

High fuel economy, high efficiency engine **New**

The AX-u series mounts a new model engine equipped with an electronic governor. Electronic accelerator pedal control allows precise engine control and delivers high fuel economy.



Fuel consumption

- AX33u: 21% reduction
- AX38u: 15% reduction
- AX48u: 4% reduction
- AX55u: 3% reduction

ECO mode / PWR mode selection **New**

The mode can be easily selected on the multi-monitor.

• ECO (economy) mode

:Priority is given to fuel economy, for conserving fuel.

• PWR (power) mode

:Priority is given to work, for when excavating power and higher work speeds are needed.

The engine speed can be adjusted to the required speed using the engine control dial.



Comfortable Operation

A large operator space in bright new colors has been created for operator relaxation and comfort.

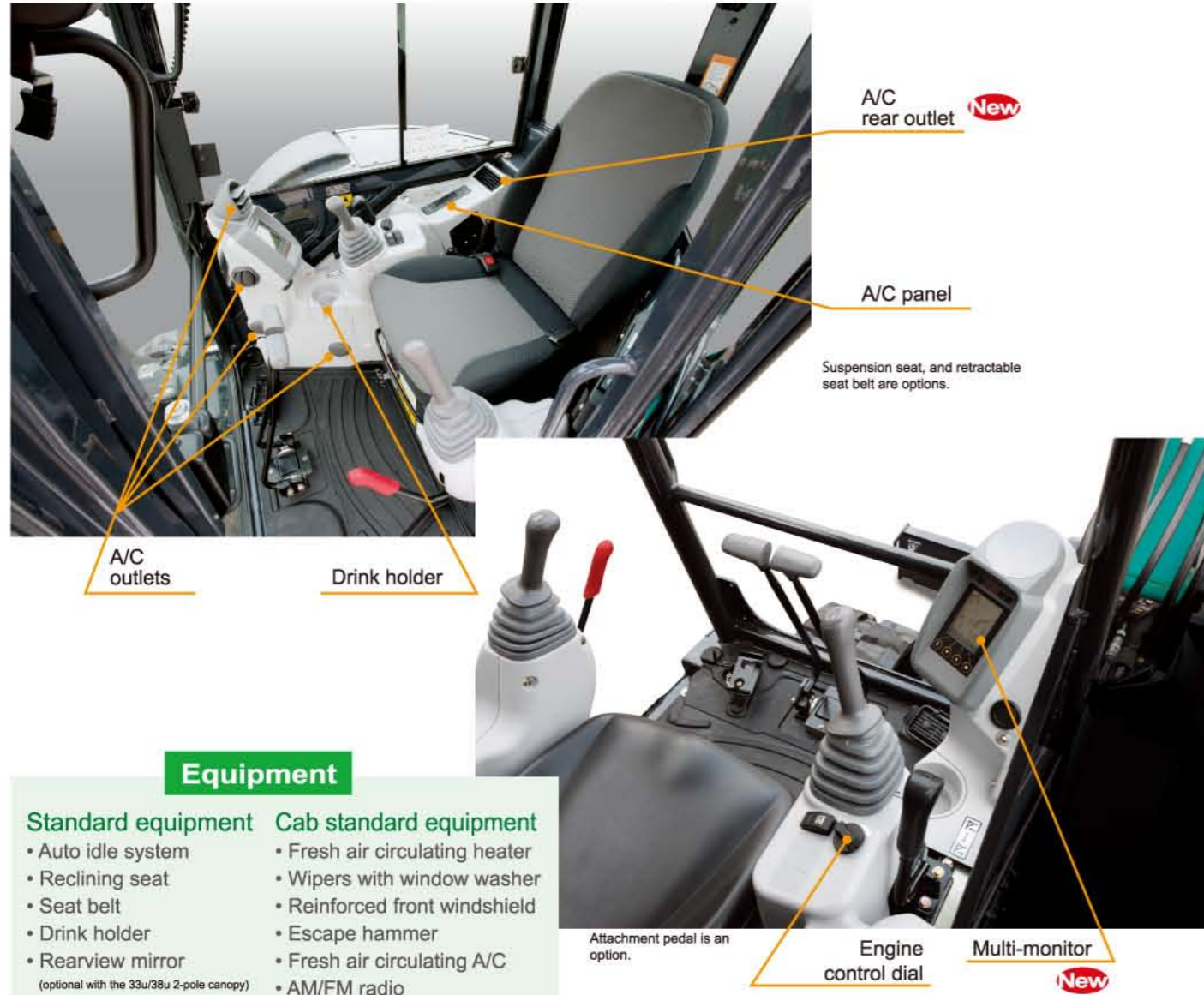

Equipment

Standard equipment

- Auto idle system
- Reclining seat
- Seat belt
- Drink holder
- Rearview mirror (optional with the 33u/38u 2-pole canopy)

Cab standard equipment

- Fresh air circulating heater
- Wipers with window washer
- Reinforced front windshield
- Escape hammer
- Fresh air circulating A/C
- AM/FM radio

Options

- Automatic idling stop
- Armrests
- Retractable seat belt
- Suspension seat
- Seat heater (canopy only)
- Extra interior power outlet (12 V)
- Travel pedal

Vibration-damping floor mounting structure

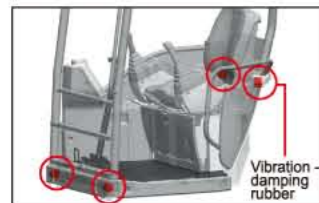

Larger vibration-damping rubber is used in the floor mounts to provide a large improvement in operator comfort.

Large working space **New**

The floor leg space has been expanded. Cab specifications also feature a roomier interior space and larger front windshield, for a larger working space. The opening size of the cab door has also been expanded for easier entry and exit.



Dependable Safety

The design gives top priority to safety, including ROPS/OPG capabilities and operator lever locks.



ROPS OPG 4-pole canopy and cabin

This structure protects the operator wearing a seat belt in the event that the machine rolls over. The structure conforms to the ROPS (Roll-Over Protective Structure) safety standard. The cab also satisfies the OPG top guard safety standard (standard for operator protective structures) to protect operators from falling objects.

Secure locks for all operating levers



The use of hydraulic pilot type operating levers allows all levers to be securely locked. A neutral engine start mechanism permits engine start only when the lock lever is locked.

Foot step for easy entry and exit **New**

A foot step provides a lower entry position. The low step makes it easier to enter and exit the vehicle.



Turning/travel parking brakes are equipped as standard.

Easy Maintenance

Large improvement in daily inspection workability.



Wide opening cover **New**

With a wide radiator side cover that can be easily opened with a latch, as well as our popular sliding-type engine cover that improves maintenance convenience in small spaces, the daily maintenance is easier than ever.

Parallel radiator and oil cooler layout **New**

The radiator and oil cooler layout has been changed from a series layout to a parallel layout, improving both cleaning convenience and cooling performance.

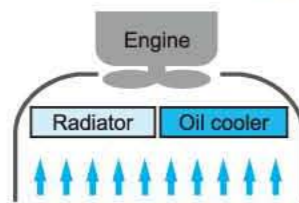

Anti-clogging radiator and oil cooler

The corrosion-resistant aluminum radiator and oil cooler utilize a wavy fin structure. This structure reduces cooling fan clogging and allows easy cleaning.



Self-lubricating bushing

Our proven self-lubricating bushing is used in the front pin joint. Grease supply interval: Daily



Split-type floor mat **New**

A split-type floor mat is used, allowing the floor part to be separately removed and cleaned. The pattern shapes have also been improved to make sweeping out the cab easier.

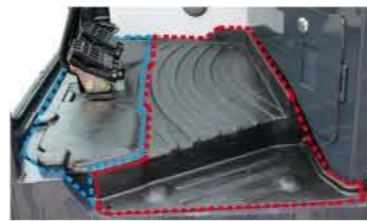

Mud splash resistant truck frame

The undercarriage resists mud packing and allows any accumulated mud to be easily removed. This allows post-work cleaning to be completed much faster.

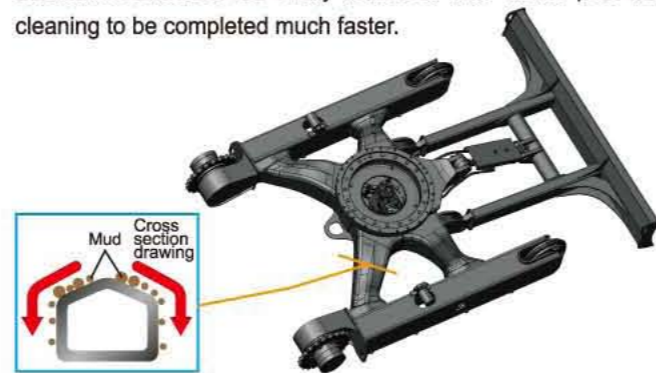

Maintenance-free turning speed reducer (type lubricated by hydraulic oil)

Grease bath-type turning gear Grease supply interval: Every 500 hours

Hydraulic oil change Oil change interval: Every 2,000 hours

Pride in Durability

Higher durability of components delivers a new, improved level of reliability.



Integrated swing post pin

A large integrated pin for the swing post is used, reducing the occurrence of looseness.



D-shape frame to protect the body from impact **New**

A frame with a D-shape cross section and improved vertical rigidity protects the operator's body in the event of an impact.



Durable flat-bottom bucket

Standard equipment with the AXu series includes a flat-bottom bucket that resists wear to the welds of the bucket bottom plate.

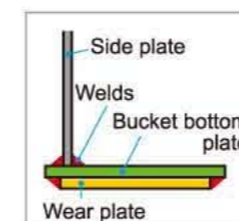

Reinforced V-shaped boom cylinder guard **New**

The V-shaped guard has been reinforced to prevent damage to the boom cylinder. Two mounting bolts are used to improve strength and prevent looseness.



Tough blade **New**

A box-section structure is used for the stays to provide greater overall blade reliability. Openings in the stays improve the flow of dirt.



High durability rubber shoes

Rubber shoes with a steel core shape provide superior durability.

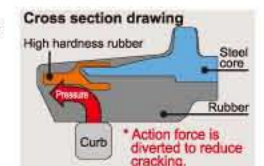

The figure shows the AX33u/38u structure.

SPECIFICATIONS AX33u/38u-6A

ENGINE

Model	Yanmar EDM-3TNV88
Type	4-cycle water-cooled, direct injection
No. of cylinders	3
Rated power	
ISO 9249, net	21.2 kW (28.4 HP) at 2,400 min ⁻¹ (rpm)
EEC 80/1269, net	21.2 kW (28.4 HP) at 2,400 min ⁻¹ (rpm)
SAE J1349, net	21.2 kW (28.4 HP) at 2,400 min ⁻¹ (rpm)
Maximum torque	105.5 Nm (10.8 kgf-m) at 1,000 min ⁻¹ (rpm)
Piston displacement	1.642 L
Bore and stroke	80 mm x 90 mm
Battery	1 x 12 V / 55 Ah

HYDRAULIC SYSTEM

Hydraulic Pumps

Main pumps	2 variable displacement axial piston pumps
	1 gear pump
Maximum oil flow	2 x 38.4 L/min
	1 x 22.8 L/min
Pilot pump	1 gear pump
Maximum oil flow	10.8 L/min

Hydraulic Motors

Travel	2 variable displacement axial piston motors
Swing	1 axial piston motor

Relief Valve Settings

Implement circuit	24.5 MPa (250 kgf/cm ²)
Swing circuit	16.7 MPa (170 kgf/cm ²)
Travel circuit	24.5 MPa (250 kgf/cm ²)
Pilot circuit	3.9 MPa (40 kgf/cm ²)

Hydraulic Cylinders

	Quantity	Bore	Rod diameter	Stroke
Boom	1	80 mm	45 mm	579 mm
	1	80 mm	45 mm	576 mm
Arm	1	70 mm	40 mm	546 mm
	1	75 mm	45 mm	597 mm
Bucket	1	65 mm	40 mm	435 mm
	1	65 mm	40 mm	435 mm
Blade	1	85 mm	45 mm	135 mm
	1	95 mm	50 mm	140 mm
Boom swing	1	85 mm	45 mm	525 mm
	1	85 mm	45 mm	525 mm

Figures in □ are date on AX33u-6A.

Figures in □ are date on AX38u-6A.

SERVICE REFIL CAPACITIES

Fuel tank	40.0 L
Engine coolant	3.9 L
Engine oil	7.2 L
Travel device (each side)	0.6 L
Hydraulic system	56.0 L
Hydraulic oil tank	32.0 L

FRONT ATTACHMENTS

BACKHOE BUCKETS

ISO 7451 capacity	Width		No. of teeth	Weight	Front Attachment			
	Without side cutters	With side cutters			AX33u-6A		AX38u-6A	
					1.17m arm	1.52m arm	1.32m arm	1.72m arm
0.04 m ³	250 mm	300 mm	3	55 kg	A	A	A	A
0.055 m ³	300 mm	350 mm	3	60 kg	A	A	A	A
0.065 m ³	350 mm	400 mm	3	65 kg	A	A	A	A
0.08 m ³	400 mm	450 mm	3	67 kg	A	A	A	A
0.09 m ³	450 mm	500 mm	4	73 kg	A	B	A	A
0.10 m ³	500 mm	550 mm	4	76 kg	B	C	A	A
0.11 m ³	550 mm	600 mm	4	80 kg	C	C	A	B
0.13 m ³	600 mm	650 mm	4	84 kg	C	-	B	C
Arm crowd force ISO					16.9 kN	14.6 kN	19.0 kN	16.9 kN
Bucket digging force ISO					27.2 kN	27.2 kN	27.1 kN	27.2 kN

A: General digging B: Light-duty digging C: Loading

UPPERSTRUCTURE

Revolving Frame

D-section frame for resistance to deformation

Swing Device

Axial piston motor with planetary reduction gear is lubricated by hydraulic oil. Swing circle is single-low. Swing parking brake is spring-set/hydraulic-released disc type.
Swing speed 9.1 min⁻¹ (rpm)
Swing torque 5.1 kN·m (558 kgf-m)

Operator's Cab

Independent spacious cabin, 1,049 mm wide by 1,611 mm high, conforming to ISO* Standards. Reinforced glass windows on 4 sides for visibility. Front windows (upper and lower) can be opened. Reclining seat.

* International Standardization Organization

UNDERCARRIAGE

Tracks

Tractor-type undercarriage. Welded track frame using selected materials. Side frame welded to track frame.

Numbers of Rollers and Shoes on Each Side

Upper rollers	1
Lower rollers	4

Travel Device

Each track driven by 2-speed axial piston motor. Parking brake is spring-set/hydraulic-released disc type.
Automatic transmission system High-Low
Travel speeds High : 0 to 4.3 km/h
..... Low : 0 to 2.8 km/h
Maximum traction force 27 kN (2,750 kgf)
Gradeability 58% (30-degree) continuous

WEIGHTS AND GROUND PRESSURE

AX33u-6A equipped with 2.28 m boom, 1.17 m arm and 0.09m³ bucket (ISO heaped). AX38u-6A equipped with 2.47m boom, 1.32 m arm and 0.11 m³ bucket (ISO heaped).

	AX33u-6A		AX38u-6A	
	Operating weight	Ground pressure	Operating weight	Ground pressure

4-Pillars Canopy version

300 mm rubber shoes	3,130 kg	28 kPa	3,540 kg	32 kPa
300 mm steel shoes	3,270 kg	29 kPa	3,680 kg	33 kPa

Cabin version

300 mm rubber shoes	3,310 kg	30 kPa	3,710 kg	33 kPa
300 mm steel shoes	3,450 kg	33 kPa	3,850 kg	35 kPa

* AX33u-6A: Including 0.09 m³ (ISO heaped) bucket weight (73 kg)

* AX38u-6A: Including 0.11 m³ (ISO heaped) bucket weight (80 kg)

LIFTING CAPACITIES

Notes: 1. Ratings are based on ISO 10567.

2. The lifting capacity of the AX series does not exceed 75% of the tipping load with the machine on firm, level ground or 87% full hydraulic capacity.

3. The load point is the center-line of the bucket pivot mounting pin on the arm.

4. *Indicates load limited by hydraulic capacity.

5. 0 m = Ground.

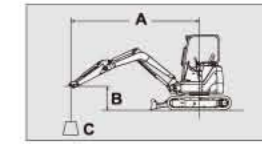

A: Load radius
B: Load point height
C: Lifting capacity

AX33u-6A Canopy Version, Blade above Ground

Rating over-front Rating over-side or 360 degrees Unit: 1,000 kg

Conditions	Load point height m	Load radius								At max. reach	
		1.0 m		2.0 m		3.0 m		4.0 m		meter	
		Rating over-front	Rating over-side or 360 degrees	Rating over-front	Rating over-side or 360 degrees	Rating over-front	Rating over-side or 360 degrees	Rating over-front	Rating over-side or 360 degrees		
Arm 1.17 m Rubber shoe 300 mm	3.0m										
	2.0m			1.01	1.40	0.54	0.71	0.34	0.45	0.34	0.44
	1.0m					0.50	0.67	0.33	0.43	0.31	0.41
	0 (Ground)			0.86	1.22	0.48	0.64			0.32	0.43
	-1.0m	*1.86	*1.86	0.87	1.24	0.48	0.64			0.40	0.52
	-2.0m			0.92	*0.98					0.80	*0.84

AX33u-6A Canopy Version, Blade on Ground

Rating over-front Rating over-side or 360 degrees Unit: 1,000 kg

Conditions	Load point height m	Load radius								At max. reach	
		1.0 m		2.0 m		3.0 m		4.0 m		meter	
		Rating over-front	Rating over-side or 360 degrees	Rating over-front	Rating over-side or 360 degrees	Rating over-front	Rating over-side or 360 degrees	Rating over-front	Rating over-side or 360 degrees		
Arm 1.17 m Rubber shoe 300 mm	3.0m										
	2.0m			1.01	*1.48	0.54	*1.00	0.34	*0.88	0.34	*0.82
	1.0m					0.50	*1.30	0.33	*0.95	0.31	*0.89
	0 (Ground)			0.86	*1.44	0.48	*1.44			0.32	*0.95
	-1.0m	*1.86	*1.86	0.87	*2.16	0.48	*1.28			0.40	*0.99
	-2.0m			0.92	*0.98					0.79	*0.84

AX38u-6A Canopy Version, Blade above Ground

Rating over-front Rating over-side or 360 degrees Unit: 1,000 kg

Conditions	Load point height m	Load radius								At max. reach	
		1.0 m		2.0 m		3.0 m		4.0 m		meter	
		Rating over-front	Rating over-side or 360 degrees	Rating over-front	Rating over-side or 360 degrees	Rating over-front	Rating over-side or 360 degrees	Rating over-front	Rating over-side or 360 degrees		
Arm 1.32 m Rubber shoe 300 mm	3.0m					0.78	*0.80			0.49	0.53
	2.0m			1.41	1.56	0.74	0.79	0.47	0.50	0.41	0.43
	1.0m					0.69	0.74	0.45	0.48	0.38	0.41
	0 (Ground)			1.21	1.34	0.66	0.70	0.44	0.47	0.39	0.42
	-1.0m	*1.87	*1.87	1.22	1.36	0.65	0.70			0.46	0.49
	-2.0m			1.27	1.40					0.73	0.79

AX38u-6A Canopy Version, Blade on Ground

Rating over-front Rating over-side or 360 degrees Unit: 1,000 kg

Conditions	Load point height m	Load radius								At max. reach	
		1.0 m		2.0 m		3.0 m		4.0 m		meter	
		Rating over-front	Rating over-side or 360 degrees	Rating over-front	Rating over-side or 360 degrees	Rating over-front	Rating over-side or 360 degrees	Rating over-front	Rating over-side or 360 degrees		
Arm 1.32 m Rubber shoe 300 mm	3.0m					0.78	*0.80			0.49	*0.82
	2.0m			1.41	*1.61	0.74	*1.05	0.47	*0.90	0.41	*0.80
	1.0m					0.69	*1.41	0.45	*1.02	0.38	*0.85
	0 (Ground)			1.21	*1.38	0.66	*1.60	0.44	*1.09	0.39	*0.97
	-1.0m	*1.87	*1.87	1.22	*2.56	0.65	*1.52			0.46	*1.02
	-2.0m			1.27	*1.69					0.73	*1.02

SPECIFICATIONS

AX48u/55u-6A

ENGINE

Model	Yanmar EDM-4TNV88
Type	4-cycle water-cooled, direct injection
No. of cylinders	4
Rated power	
ISO 9249, net	28.2 kW (37.8 HP) at 2,400 min ⁻¹ (rpm)
EEC 80/1269, net	28.2 kW (37.8 HP) at 2,400 min ⁻¹ (rpm)
SAE J1349, net	28.2 kW (37.8 HP) at 2,400 min ⁻¹ (rpm)
Maximum torque	139.6 Nm (14.2 kgf-m) at 1,100 min ⁻¹ (rpm)
Piston displacement	2.189 L
Bore and stroke	88 mm x 90 mm
Battery	1 x 12 V / 72 Ah

HYDRAULIC SYSTEM

Hydraulic Pumps

Main pumps	1 variable displacement axial piston pump
Maximum oil flow	1 x 120 L/min
Pilot pump	1 gera pump
Maximum oil flow	12.0 L/min

Hydraulic Motors

Travel	2 variable displacement axial piston motors
Swing	1 axial piston motor

Relief Valve Settings

Implement circuit	24.5 MPa (250 kgf/cm ²)
Swing circuit	18.3 MPa (187 kgf/cm ²)
Travel circuit	24.5 MPa (250 kgf/cm ²)
Pilot circuit	5.9 MPa (60.2 kgf/cm ²)

Hydraulic Cylinders

	Quantity	Bore	Rod diameter	Stroke
Boom	1	90 mm	55 mm	699 mm
	1	95 mm	55 mm	699 mm
Arm	1	80 mm	50 mm	698 mm
	1	80 mm	50 mm	731 mm
Bucket	1	70 mm	40 mm	551 mm
	1	75 mm	45 mm	551 mm
Blade	1	105 mm	50 mm	140 mm
	1	105 mm	50 mm	140 mm
Boom swing	1	90 mm	50 mm	666 mm
	1	90 mm	50 mm	666 mm

Figures in □ are date on AX48u-6A.

Figures in □ are date on AX55u-6A.

SERVICE REFIL CAPACITIES

Fuel tank	70.0 L
Engine coolant	4.7 L
Engine oil	8.6 L
Travel device (each side)	0.9 L
Hydraulic system	66.0 L
Hydraulic oil tank	42.0 L

FRONT ATTACHMENTS

BACKHOE BUCKETS

ISO 7451 capacity	Width		No. of teeth	Weight	Front Attachment			
	Without side cutters	With side cutters			AX48u-6A		AX55u-6A	
					1.38 m arm	1.69 m arm	1.38 m arm	1.69 m arm
0.10 m ³	350mm	400mm	3	92 kg	A	A	A	A
0.11 m ³	400 mm	450mm	3	96 kg	A	A	A	A
0.13 m ³	450 mm	500 mm	4	104 kg	A	B	A	A
0.14 m ³	500 mm	600 mm	4	109 kg	A	C	A	A
0.16 m ³	600 mm	650 mm	4	113 kg	C	C	A	B
0.17 m ³	650 mm	700 mm	4	120 kg	C	C	B	C
Arm crowd force					24.0 kN	21.0 kN	24.0 kN	21.0 kN
Bucket digging force					32.1 kN	32.1 kN	36.8 kN	36.9 kN

A: General digging B: Light-duty digging C: Loading

UPPERSTRUCTURE

Revolving Frame

D-section frame for resistance to deformation

Swing Device

Axial piston motor with planetary reduction gear is lubricated by hydraulic oil. Swing circle is single-low. Swing parking brake is spring-set/hydraulic-released disc type.

Swing speed	9.0 min ⁻¹ (rpm)
Swing torque	8.6 kN-m (877 kgf-m)

Operator's Cab

Independent spacious cabin, 1,049 mm wide by 1,611 mm high, conforming to ISO* Standards. Reinforced glass windows on 4 sides for visibility. Front windows (upper and lower) can be opened. Reclining seat.

* International Standardization Organization

UNDERCARRIAGE

Tracks

Tractor-type undercarriage. Welded track frame using selected materials. Side frame welded to track frame.

Numbers of Rollers and Shoes on Each Side

Upper rollers	1
Lower rollers	4

Travel Device

Each track driven by 2-speed axial piston motor. Parking brake is spring-set/hydraulic-released disc type. Automatic transmission system High-Low. Travel speeds High : 0 to 4.2 km/h Low : 0 to 2.5 km/h. Maximum traction force 38.3 kN (3,905 kgf). Gradeability 58% (30-degree) continuous.

WEIGHTS AND GROUND PRESSURE

AX48u-6A equipped with 2.68 m boom, 1.38 m arm and 0.14 m³ bucket (ISO heaped). AX55u-6A equipped with 2.85 m boom, 1.38 m arm and 0.16 m³ bucket (ISO heaped).

	AX48u-6A		AX55u-6A	
	Operating weight	Ground pressure	Operating weight	Ground pressure
4-Poles Canopy version				
400 mm rubber shoes	4,540 kg	26 kPa	4,850 (5,080) kg	27 (29) kPa
400 mm steel shoes	4,650 kg	26 kPa	4,960 (5,190) kg	28 (29) kPa
Cabin version				
400 mm rubber shoes	4,670 kg	26 kPa	4,980 (5,210) kg	28 (29) kPa
400 mm steel shoes	4,780 kg	27 kPa	5,090 (5,320) kg	29 (30) kPa

4-Poles Canopy version

400 mm rubber shoes	4,540 kg	26 kPa	4,850 (5,080) kg	27 (29) kPa
400 mm steel shoes	4,650 kg	26 kPa	4,960 (5,190) kg	28 (29) kPa

Cabin version

400 mm rubber shoes	4,670 kg	26 kPa	4,980 (5,210) kg	28 (29) kPa
400 mm steel shoes	4,780 kg	27 kPa	5,090 (5,320) kg	29 (30) kPa

* AX48u-6A: including 0.14 m³ (ISO heaped) bucket weight (109 kg).

* AX55u-6A: including 0.16 m³ (ISO heaped) bucket weight (113 kg).

LIFTING CAPACITIES

Notes: 1. Ratings are based on ISO 10567.

2. The lifting capacity of the AX series does not exceed 75% of the tipping load with the machine on firm, level ground or 87% full hydraulic capacity.

3. The load point is the center-line of the bucket pivot mounting pin on the arm.

4. *Indicates load limited by hydraulic capacity.

5. 0 m = Ground.

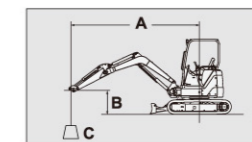

A: Load radius

B: Load point height

C: Lifting capacity

AX48u-6A Canopy Version, Blade above Ground

Rating over-front Rating over-side or 360 degrees Unit: 1,000 kg

Conditions	Load point height m	Load radius								At max. reach		
		2.0 m		3.0 m		4.0 m		5.0 m				
		Rating over-front	Rating over-side or 360 degrees	Rating over-front	Rating over-side or 360 degrees	Rating over-front	Rating over-side or 360 degrees	Rating over-front	Rating over-side or 360 degrees	meter	meter	
Arm 1.38 m	3.0m			1.13	*1.19	0.71	0.87			0.59	0.73	4.47
Rubber shoe 400 mm	2.0m			1.05	1.34	0.68	0.85			0.51	0.63	4.83
	1.0m			0.97	1.25	0.65	0.81			0.48	0.60	4.91
	0 (Ground)			0.94	1.21	0.63	0.79			0.5	0.63	4.73
	-1.0m	1.83	2.53	0.94	1.21	0.63	0.79			0.58	0.73	4.25
	-2.0m	1.88	*2.05	0.97	1.25					0.86	1.09	3.28

AX48u-6A Canopy Version, Blade on Ground

Rating over-front Rating over-side or 360 degrees Unit: 1,000 kg

Conditions	Load point height m	Load radius								At max. reach		
		2.0 m		3.0 m		4.0 m		5.0 m				
		Rating over-front	Rating over-side or 360 degrees	Rating over-front	Rating over-side or 360 degrees	Rating over-front	Rating over-side or 360 degrees	Rating over-front	Rating over-side or 360 degrees	meter	meter	
Arm 1.38 m	3.0m			1.13	*1.19	0.71	*1.11			0.59	*1.06	4.47
Rubber shoe 400 mm	2.0m			1.05	*1.66	0.68	*1.25			0.51	*1.07	4.83
	1.0m			0.97	*2.16	0.65	*1.43			0.48	*1.14	4.91
	0 (Ground)			0.94	*2.28	0.63	*1.50			0.5	*1.17	4.73
	-1.0m	1.83	*3.06	0.94	*2.04	0.63	*1.34			0.58	*1.19	4.25
	-2.0m	1.88	*2.05	0.97	*1.31					0.86	*1.10	3.28

AX55u-6A Canopy Version, Blade above Ground

Rating over-front Rating over-side or 360 degrees Unit: 1,000 kg

Conditions	Load point height m	Load radius								At max. reach		
		2.0 m		3.0 m		4.0 m		5.0 m				
		Rating over-front	Rating over-side or 360 degrees	Rating over-front	Rating over-side or 360 degrees	Rating over-front	Rating over-side or 360 degrees	Rating over-front	Rating over-side or 360 degrees	meter	meter	
Arm 1.38 m	3.0m			*1.26	*1.26	0.84	1.00			0.65	0.77	4.69
Rubber shoe 400 mm	2.0m			1.24	1.51	0.81	0.97	0.58	0.69	0.57	0.68	5.03
	1.0m			1.15	1.42	0.77	0.93	0.56	0.67	0.55	0.65	5.11
	0 (Ground)			1.12	1.39	0.75	0.91			0.57	0.68	4.94
	-1.0m	2.20	*2.68	1.13	1.39	0.75	0.91			0.65	0.78	4.49
	-2.0m	2.25	*2.69	1.16	1.42					0.89	1.08	3.61

AX55u-6A Canopy Version, Blade on Ground

Rating over-front Rating over-side or 360 degrees Unit: 1,000 kg

Conditions	Load point height m	Load radius								At max. reach		
		2.0 m		3.0 m		4.0 m		5.0 m				
		Rating over-front	Rating over-side or 360 degrees	Rating over-front	Rating over-side or 360 degrees	Rating over-front	Rating over-side or 360 degrees	Rating over-front	Rating over-side or 360 degrees	meter	meter	
Arm 1.38 m	3.0m			*1.26	*1.26	0.84	*1.17			0.65	*0.91	4.69
Rubber shoe 400 mm	2.0m			1.24	*1.86	0.81	*1.36	0.58	*1.06	0.57	*0.91	5.03
	1.0m			1.15	*2.43	0.77	*1.58	0.56	*1.24	0.55	*0.97	5.11
	0 (Ground)			1.12	*2.56	0.75	*1.69			0.57	*1.13	4.94
	-1.0m	2.20	*2.68	1.13	*2.34	0.75	*1.58			0.65	*1.28	4.49
	-2.0m	2.25	*2.69	1.16	*1.73					0.89	*1.25	3.61

DIMENSIONS & WORKING RANGES

● DIMENSIONS & WORKING RANGES

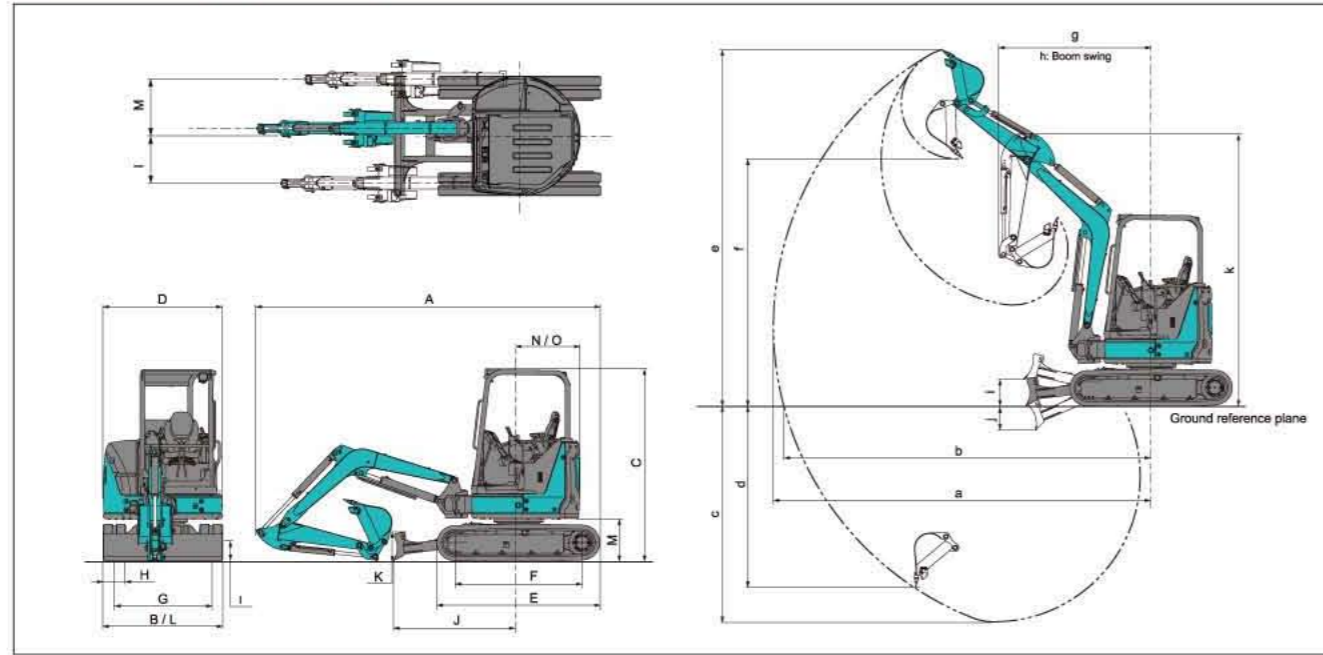

● DIMENSIONS & WORKING RANGES

Unit: mm

Item	Model	Rubber shoe							
		AX33u-6A		AX38u-6A		AX48u-6A		AX55u-6A	
Shoe type		Canopy	Cabin	Canopy	Cabin	Canopy	Cabin	Canopy	Cabin
Roof type									
DIMENSIONS	A: Max. Transport length	mm 4,450 (4,530)		4,640 (4,760)		5,350 (5,390)		5,470 (5,520)	
	B: Undercarriage width	mm 1,550		1,740		1,960		2,000	
	C: Overall height	mm 2,480		2,480		2,530		2,530	
	D: Upperstructure width	mm 1,550		1,550		1,850		1,850	
	E: Undercarriage length	mm 2,110		2,110		2,500		2,500	
	F: Sprocket center to idler center	mm 1,660		1,660		2,000		2,000	
	G: Distance between undercarriage cent	mm 1,250		1,440		1,560		1,600	
	H: Track shoe width	mm 300		300		400		400	
	I: Min. Ground clearance	mm 280		280		340		340	
	J: Parallel blade distance	mm 1,620		1,620		1,820		1,820	
	K: Blade height	mm 360		360		375		375	
	L: Blade width	mm 1,550		1,740		1,960		2,000	
	M: Counterweight clearance	mm 550		550		610		610	
	N: Rear edge length	mm 875		980		1,080		1,100	
	O: Rear edge swing radius	mm 875		980		1,080		1,100	
	WORKING RANGES	a: Max. digging reach	mm 4,890 (5,170)		5,210 (5,520)		5,760 (6,060)		5,960 (6,260)
b: Max. digging reach at ground		mm 4,750 (5,040)		5,080 (5,410)		5,610 (5,920)		5,820 (6,130)	
c: Max. digging depth		mm 2,790 (3,130)		3,060 (3,460)		3,320 (3,630)		3,530 (3,830)	
d: Max. vertical wall		mm 2,330 (2,530)		2,580 (2,780)		2,550 (2,880)		2,810 (3,140)	
e: Max. cutting height		mm 4,620 (4,700)	4,420 (4,470)	4,870 (4,950)	4,700 (4,740)	5,590 (5,820)	5,750 (6,000)		
f: Max. dumping height		mm 3,200 (3,310)	3,030 (3,100)	3,460 (3,570)	3,310 (3,390)	3,910 (4,140)	4,070 (4,310)		
g: Min. swing radius		mm 1,970 (2,090)	2,150 (2,180)	2,080 (2,190)	2,240 (2,300)	2,240 (2,370)	2,210 (2,300)		
h: Max. boom swing radius		mm 1,580 (1,680)	1,820 (1,860)	1,670 (1,770)	1,910 (1,970)	1,750 (1,860)	1,730 (1,810)		
i: Blade bottom highest position		mm 360		360		460		460	
j: Blade bottom lowest position		mm 320		400		365		365	
k: Front height at min. swing radius		mm 3,530 (3,560)	3,440 (3,460)	3,720 (3,760)	3,640 (3,680)	4,250	4,380		
l/m: Offset distance		mm 610/735	610/700	610/735	610/700	690/850	690/850		
Max. Boom-swing angle	deg. 72/62	62/62	72/62	62/62	80/60	80/60			

Figure in () show the machine equipped with a long arm.

EQUIPMENT

Standard and optional equipment may vary by country, so please consult your AIRMAN dealer for details.

● STANDARD EQUIPMENT

- ### ENGINE
- Auto idle system
 - Cartridge-type engine oil filter
 - Electrical fuel feed pump
 - Fuel main filter
 - Radiator reserve tank
 - Water-separator for engine fuel
 - Air cleaner inner element

- ### HYDRAULIC SYSTEM
- Boom anti-drift valve
 - Full-flow filter
 - Hydraulic pilot type control levers
 - Pilot control shut-off lever with neutral engine start system
 - Pilot filter
 - Suction filter
 - Swing parking brake
 - Travel parking brake
 - Two-speed travel system
 - Valve for extra piping

- ### CABIN
- Air conditioner
 - AM/FM radio
 - Anti-slip plate
 - Armrests
 - Defroster
 - Drink holder
 - Electric horn
 - Floor mat
 - Reclining seat
 - ROPS/OPG cab
 - Spare power supply
 - Window washer
 - Wiper

- ### FRONT ATTACHMENTS
- Original bushing
 - Extra piping
 - 1.17 m STD arm (AX33u-6A)
 - 1.32 m STD arm (AX38u-6A)
 - 1.38 m STD arm (AX48_55u-6A)

- ### 4-POLE CANOPY
- Anti-slip plate
 - Armrests
 - Drink holder
 - Electric horn
 - Floor mat
 - Reclining seat
 - ROPSD/OPG canopy
 - Spare power supply

- ### UPPERSTRUCTURE
- Rear view mirror
 - Tool box (AX48_55u-6A)

- ### UNDERCARRIAGE
- 300 mm rubber shoe (AX33_38u-6A)
 - 400 mm rubber shoe (AX48_55u-6A)

● OPTIONAL EQUIPMENT

- ### ENGINE
- Dust-Proof indoor net

- ### HYDRAULIC SYSTEM
- Hose rupture valve (HRV)

- ### CABIN
- Auxiliary function lever (AFL)
 - Heater
 - Retractable seat belt
 - Suspension seat
 - Spare power supply(outside)

- ### 4-POLE CANOPY
- Auxiliary function lever (AFL)
 - Retractable Seat belt
 - Suspension Seat

- ### FRONT ATTACHMENTS
- Assist piping
 - 1.52 m long arm (AX33u-6A)
 - 1.72 m long arm (AX38u-6A)
 - 1.69 m long arm (AX48_55u-6A)

- ### UPPERSTRUCTURE
- Auxiliary overload relief valve (ORV)
 - Pilot accumulator
 - Stack muffler
 - Travel motion alarm device
 - Additional counterweight

- ### UNDERCARRIAGE
- 300 mm grouser shoe (AX33_38u-6A)
 - 300 mm pad crawler shoe (AX33_38u-6A)
 - 400 mm grouser shoe (AX48_55u-6A)
 - 400 mm pad crawler shoe (AX48_55u-6A)

- ### MISCELLANEOUS
- Theft deterrent system*

*Hokuetsu Industries cannot be held liable for theft, any system will just minimize the risk of theft.